



Inaugural RISE

Cohort:

Finland 2027



Agenda

1. Travel Itinerary
2. Explanation of Credit Options
3. Course Assignments
4. Cost and Application Timeline
5. Q & A
6. Survey

All information on the following slides is tentative and subject to change.





HOFSTRA
UNIVERSITY

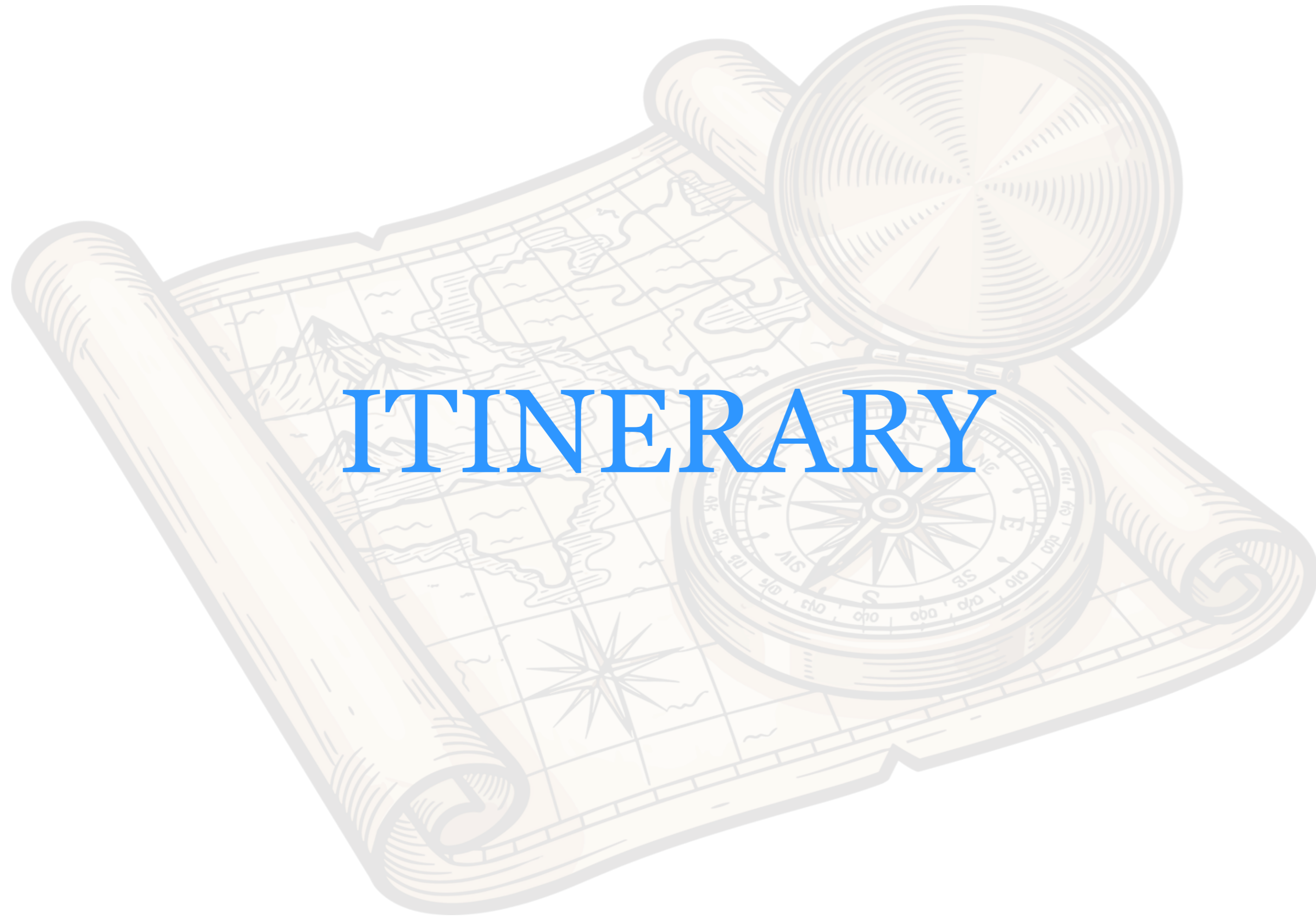

ITINERARY



Hofstra in Finland: RISE

ITINERARY: March 12-20, 2027

**DAY 0
FRI MAR 12:
DEPART USA**

- Overnight flight from JFK-HEL

**DAY 1
SAT MAR 13:
ARRIVE
HELSINKI
[-/-/D]**

- Meet private coach with guide to hotel (~40 mins)
- Lunch on own expense (guide can offer suggestions)
- Guide will help you familiarize yourself with the hotel surroundings on an orientation walking tour, and will point things out like a local grocery store, bank/ATM, post office, tram stop, etc.
- Welcome dinner at local restaurant
- Overnight at Scandic Grand Marina

DAY 2
SUN MAR 14:
HELSINKI
[B/-/-]

- Breakfast at hotel
- Use public transit to explore the city on a guided tour of Helsinki landmarks.
- Lunch on own expense
- Attend a lecture to gain expert insight into the Finnish education system and Education Policy
- Dinner at own expense
- Overnight at Scandic Grand Marina

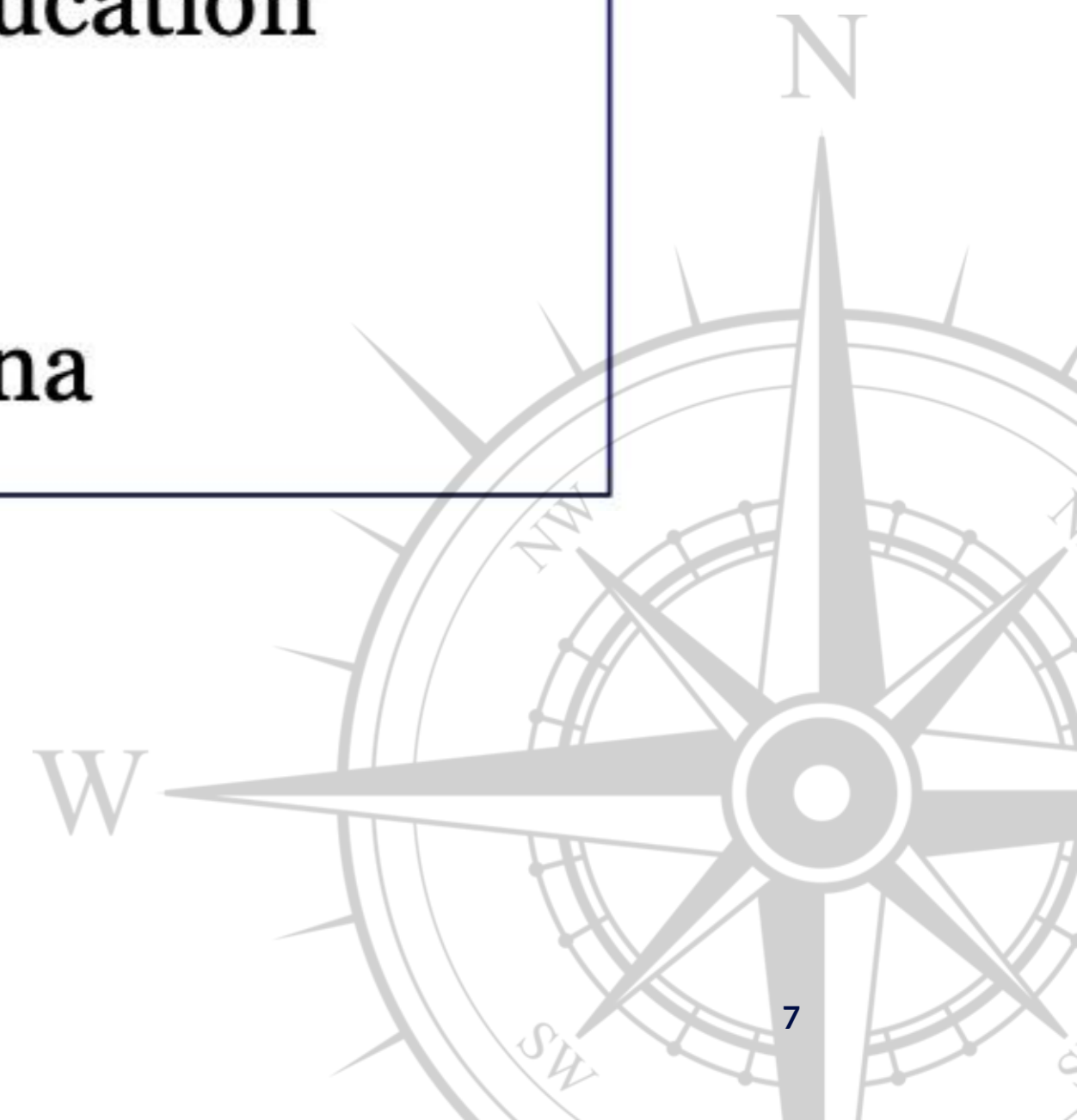

DAY 3
MON MAR 15:
HELSINKI
[B/-/-]

- Breakfast at hotel
- Meet local guide and private coach
- Visit a primary school just outside Helsinki
- Then transfer to Helsinki's Oodi Library
- Enjoy lunch there on your own expense, a guided tour, and time to explore
- Guided tour of the Parliament of Finland to learn about the political system and legislative process
- Dinner at own expense
- Overnight at Scandic Grand Marina

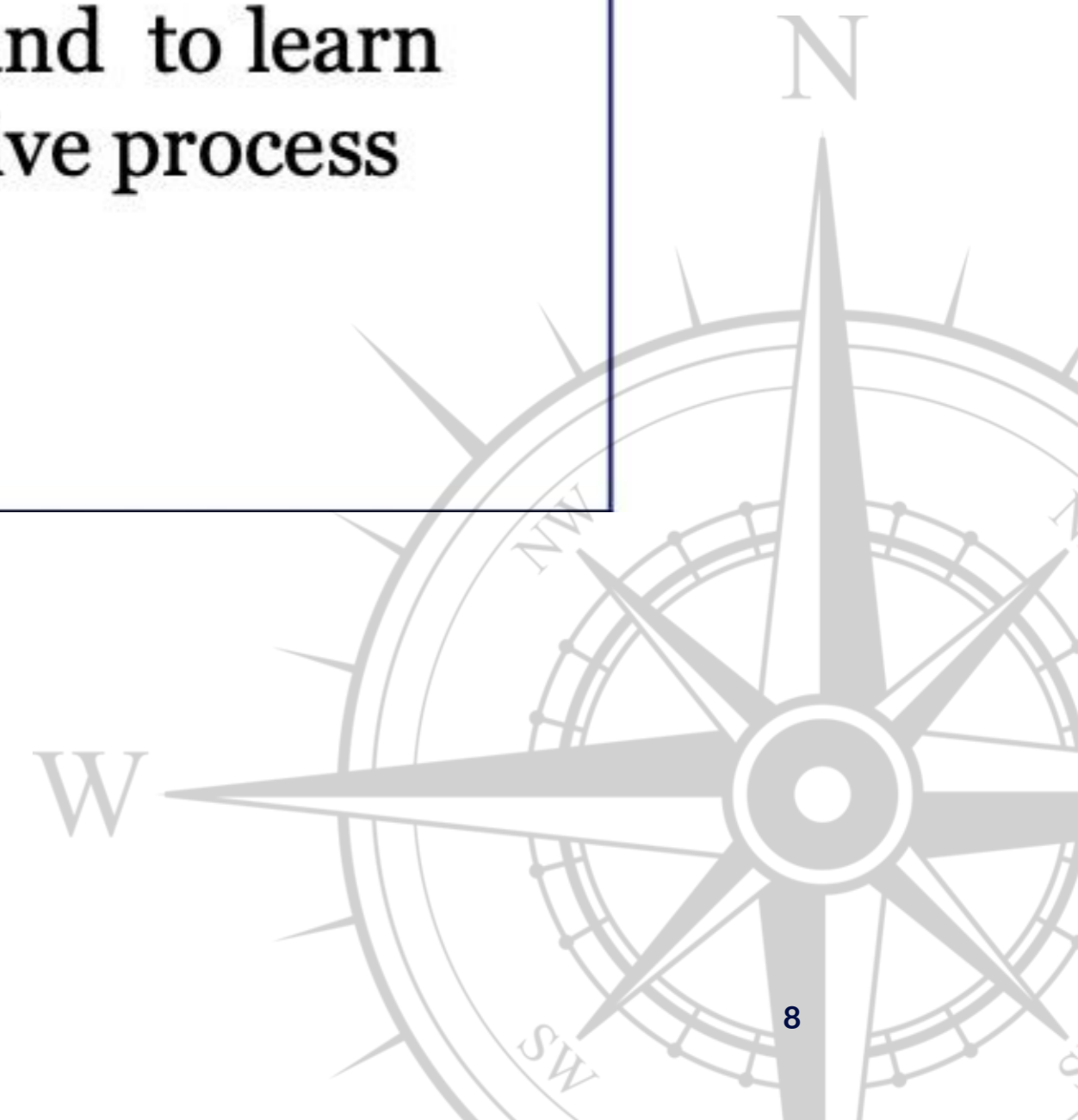

DAY 4
TUE MAR 16:
HELSINKI
[B/-/-]

- Breakfast at hotel
- Meet local guide and private coach
- Transfer to your morning visit at a secondary school in the greater Helsinki area.
- After, coach transfer to ferry port area, with time for lunch at your own expense
- Then met your Suomenlinna guide and explore the UNESCO-listed Suomenlinna Fortress located in the archipelago off Helsinki, only about a 15-minute ferry ride from central Helsinki
- Return by ferry to the mainland
- Dinner at own expense
- Overnight at Scandic Grand Marina

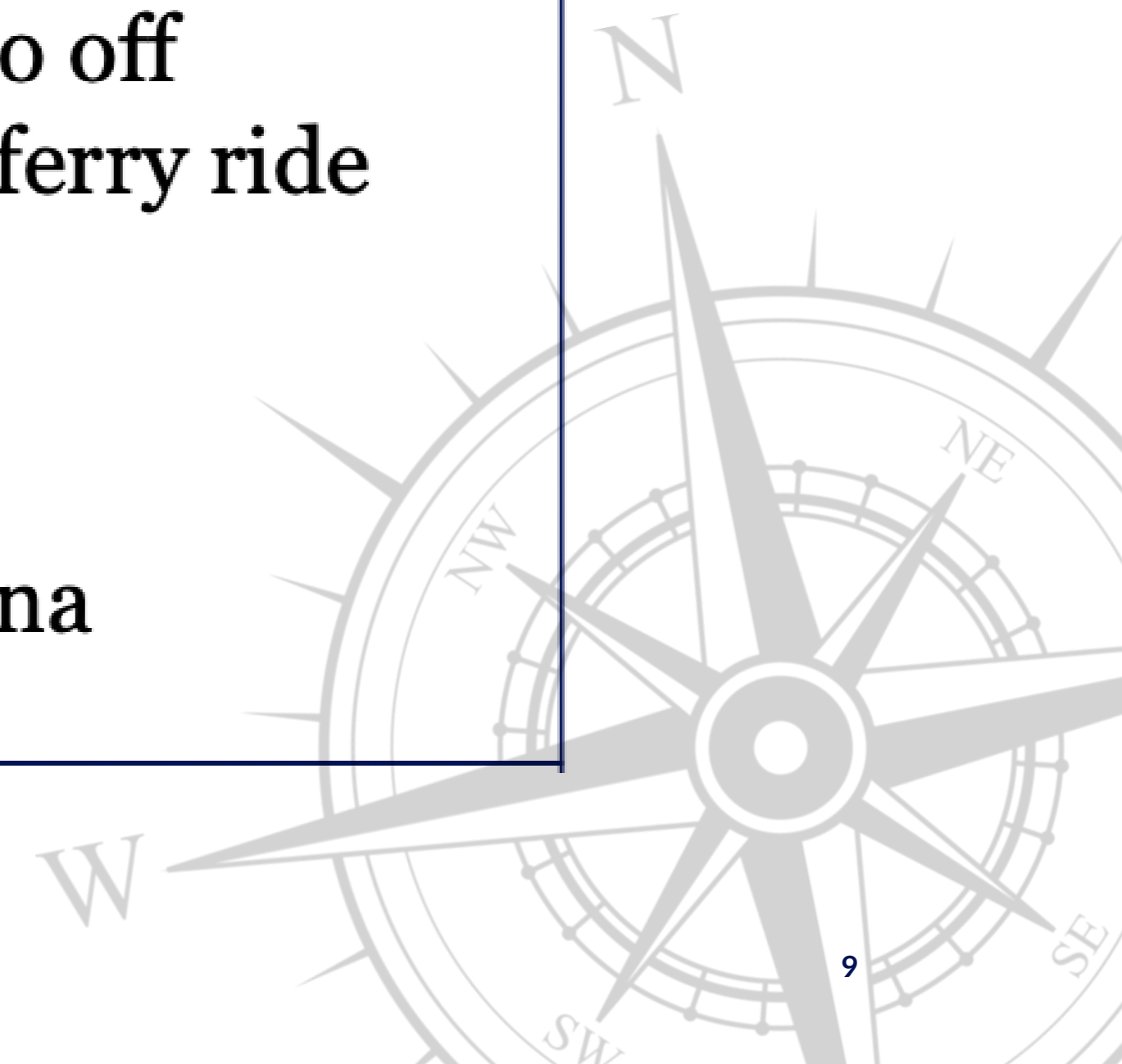

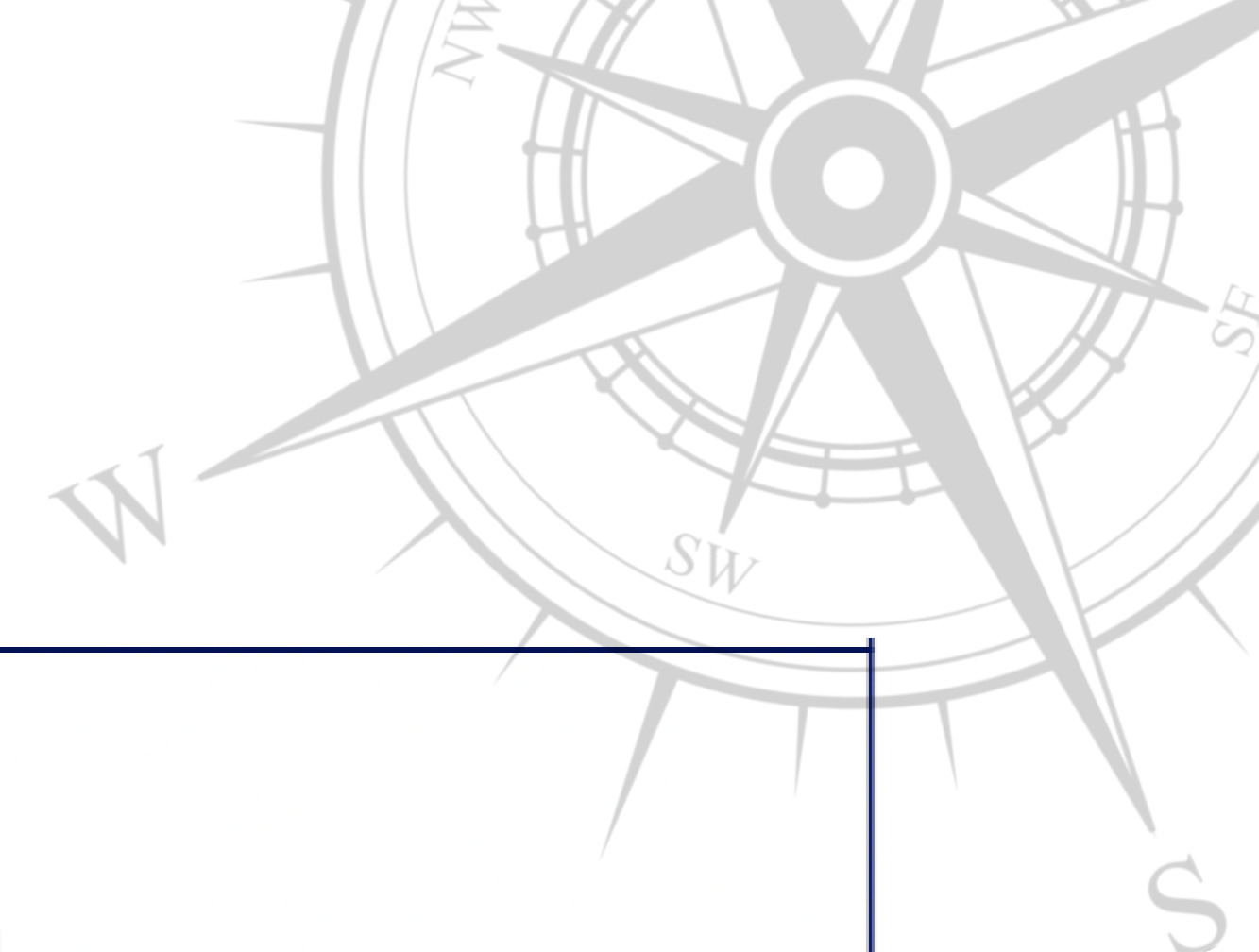

DAY 5
WED MAR 17:
HELSINKI -
LAHTI -
HELSINKI
[B/-/-]

- Breakfast at Hotel
- Meet local guide and private coach
- Transfer to Lahti, Finland's winter sports capital
- Learn about Finland's pre-school education practices during a visit to a daycare center in Lahti
- Lunch on own expense
- Observe classroom activities during a visit to an International Upper Secondary School in Lahti
- Dinner on own expense
- Overnight at Scandic Grand Marina

DAY 6
THU MAR 18:
HELSINKI -
TURKU -
HELSINKI
[B/L/-]

- Breakfast at hotel
- Meet local guide and private coach
- Visit Turku Vocational Institute to learn how Finland manages vocational education, then a tour of the facilities
- Pick up safety gear and visit a construction site where vocational students apply their skills
- Group lunch included today
- Visit Turku Castle, one of Finland's most iconic historical medieval landmarks
- Dinner on own expense
- Overnight at Scandic Grand Marina

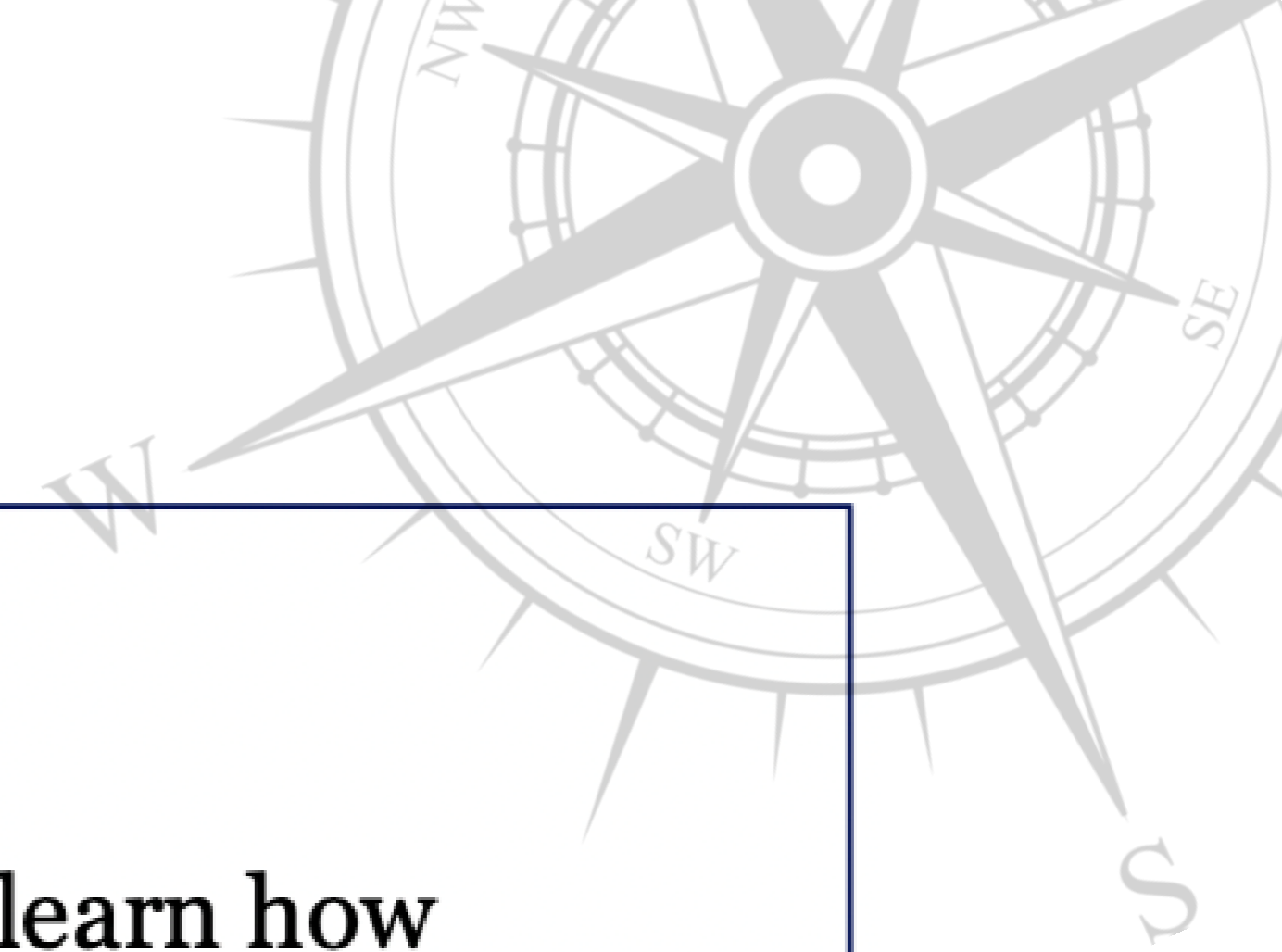

DAY 7
FRI MAR 19:
HELSINKI
[B/-/D]

- Breakfast at hotel
- Meet local guide and private coach
- Attend a lecture on the topic of teacher training at the Vikki Campus of Helsinki University
- Lunch on own expense
- Faculty-led closing discussion
- Remainder of day free to explore on own
- Farewell dinner at a local restaurant
- Overnight at Scandic Grand Marina

DAY 8
SAT MAR 20:
RETURN USA
[B/-/-]

- Breakfast at Hotel, followed by check-out
- Meet coach driver and transfer to Helsinki airport via private coach
- Afternoon flight back home from HEL-JFK





HOFSTRA
UNIVERSITY

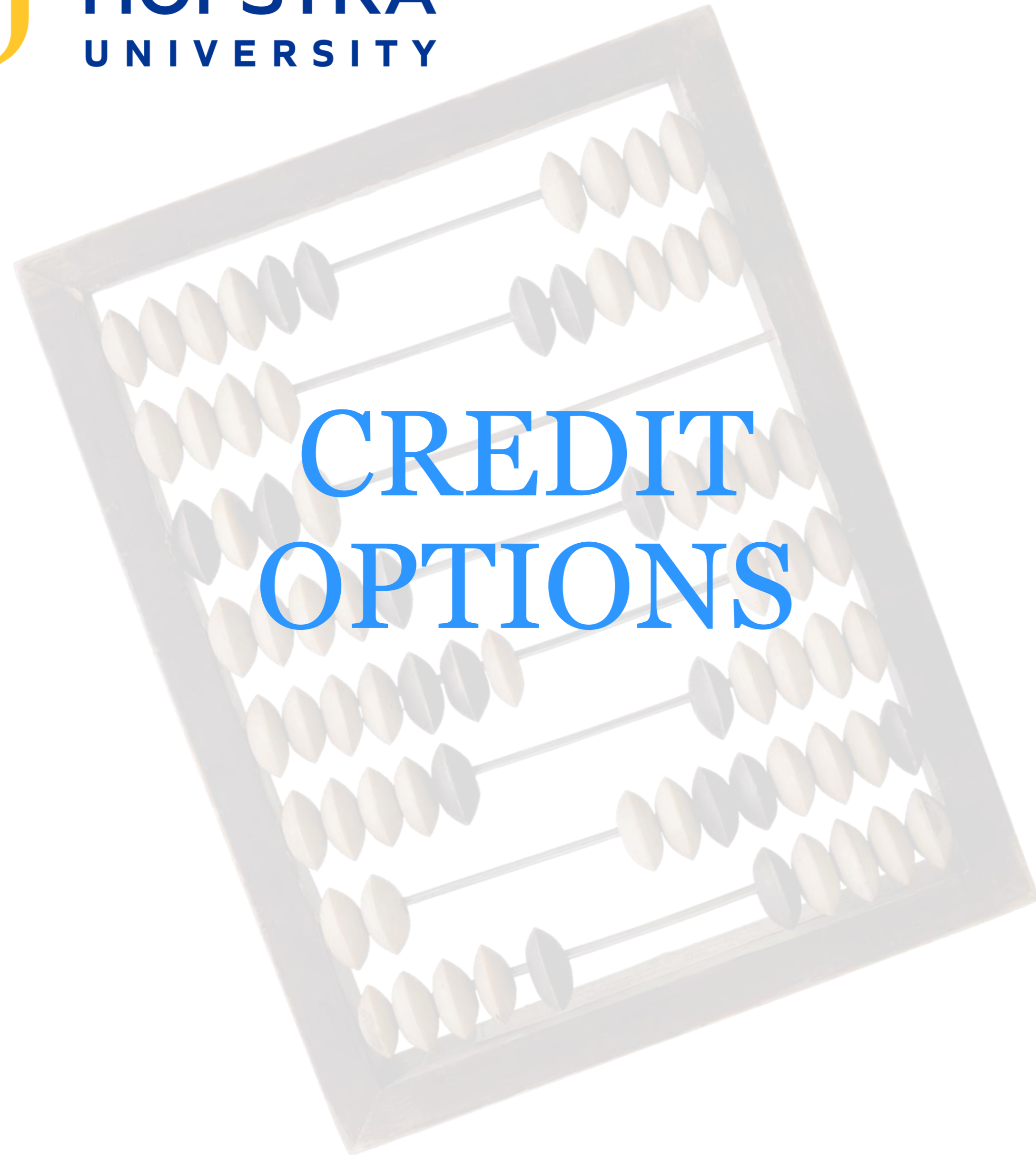

CREDIT OPTIONS



CT 203

- CT 203 is a 3-credit graduate course that can be taken by undergrads, grads, or alumni in the SOE and SHS.
- Students in DD program CAN take it as an elective for their programs.
- Students in their student teaching in internship semesters CAN take the course.

Why 0 or 3 credits?

If you take the course for 0 credits, you are still required to complete all assignments.

If possible, taking it for 3 credits is the best option because:

- This course may transfer into another program if you choose to get another degree.
- You have to complete all the work.
- Teacher pay scales are credit dependent, so even if it doesn't count for your current program, it will count as credits in the future to increase your salary.



HOFSTRA
UNIVERSITY

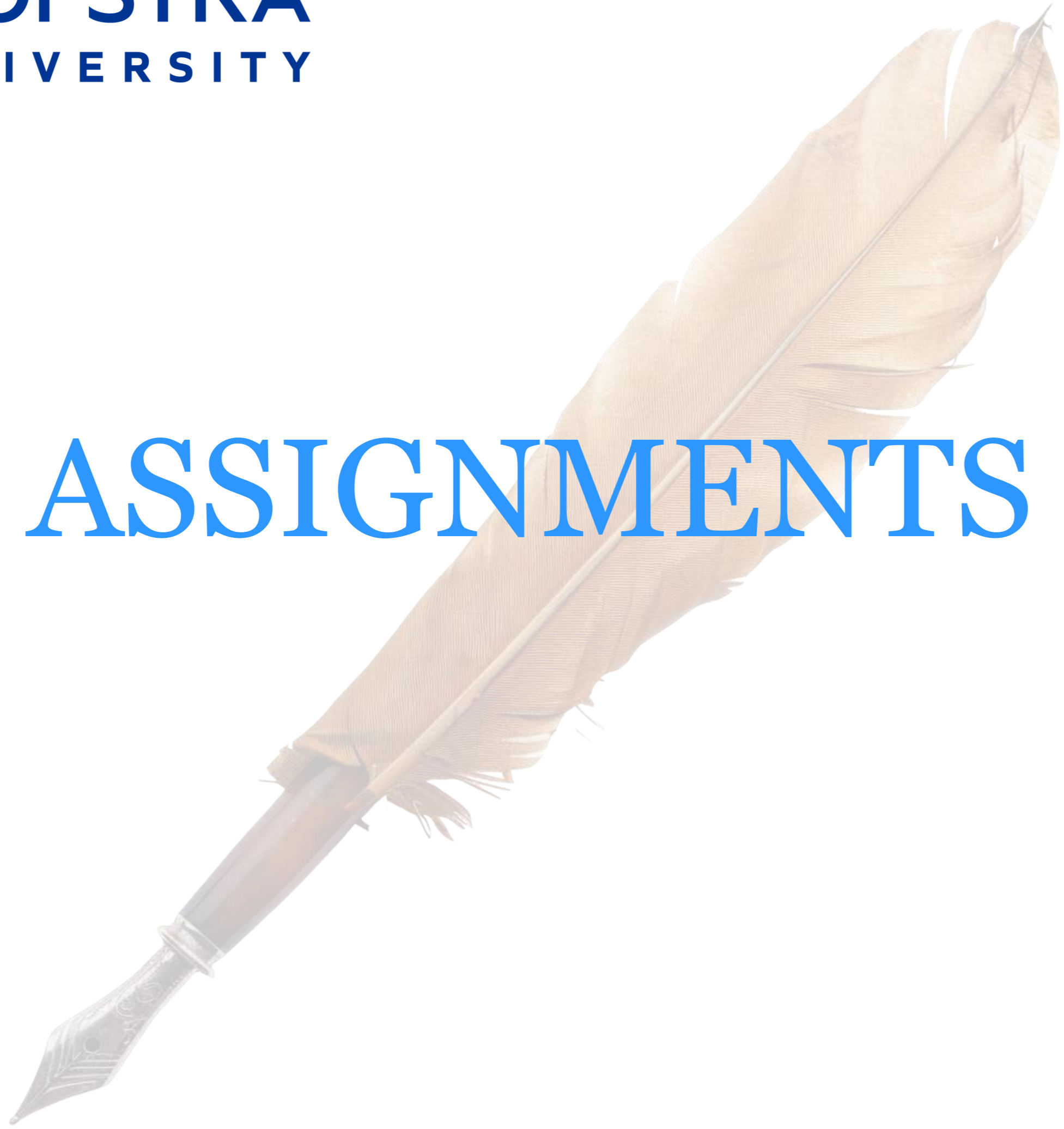

ASSIGNMENTS



1. Pre-Departure Assignments (Contextualization)

Country Education Brief: Students will research and summarize the educational system of the host country, highlighting structure, governance, funding, curriculum, teacher preparation, and issues of equity and access. Students may submit a 2-page written paper or a 3-4-minute recorded presentation. This assignment prepares students to contextualize their field experiences abroad. (10%)

Learning Goals Statement: Students will articulate 2-3 personal and professional learning goals for the study abroad experience. Goals should relate to students' development as educators and global citizens and will be revisited during the final reflection 1 page max. (10%)

2) During-Travel Assignment (Field-Based Learning)

Daily Reflective Journal: Each entry (about 250 words) should respond to provided prompts and connect experiences to course concepts. Journals will be submitted at the end of the travel week. (20%)

Participation: Participation will be evaluated based on students' active engagement during site visits, including thoughtful questioning, contributions to group discussions, and demonstrated curiosity about educational practices observed. Students are expected to interact respectfully with hosts and peers and contribute to reflective dialogue throughout the travel week. (10%)

This assignment has the option to be done in a group of 2-3.
3) Post-Travel Assignments (Integration and Analysis)

- **Culminating Project (Choose one) (30)**

Comparative Analysis Paper: (5 pages)

Photo-Ethnography Project: (6-8 photos w/ 150-word captions)

Digital Storytelling/Video Reflection: (3-5 minutes)

- **Presentation or Poster Session:** Students will present their findings and insights to peers and faculty through an oral presentation or poster session at the RISE Symposium in May. The presentation will be based on their completed assignment from above and highlight key findings and implications for educators. (20%)



HOFSTRA
UNIVERSITY



TIME & MONEY

The price of the trip will depend on several items:

- Fluctuations in airfare
- Dollar to Euro rate
- Number of people attending (max 25)

Tentative Range:

\$3,800 - \$4,850

Includes: Airfare, lodging, airport transfers, private coach, dedicated guide, entrance to heritage sites, breakfast all days, 2 dinners, 1 lunch.

TIMELINE

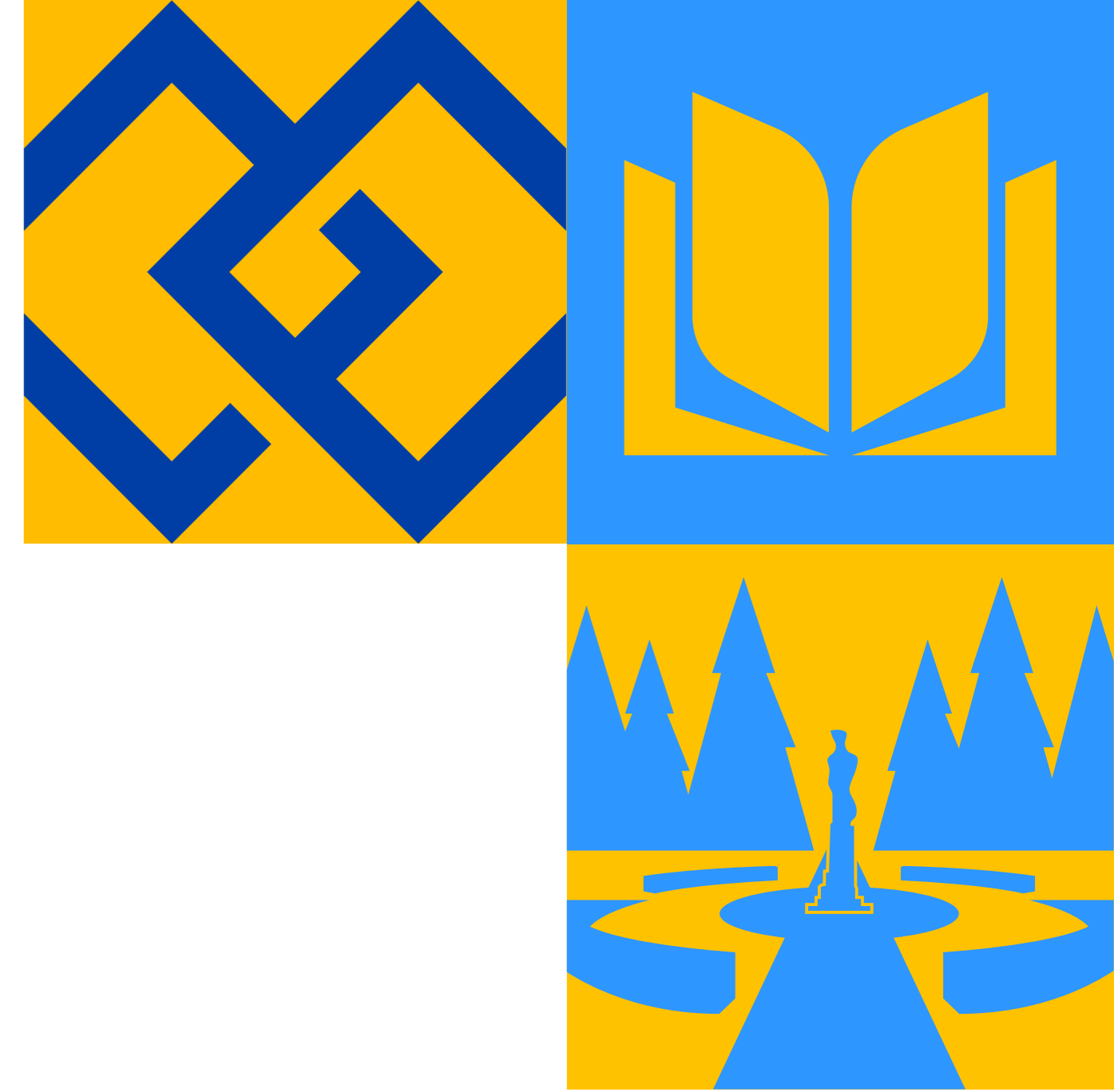

Mid-May 2026

Applications
Open

August 31, 2026

Applications Close

October 1, 2026

Decision
Notification

Mid-October 2026

Register for CT 203



HOFSTRA
UNIVERSITY

QUESTIONS ?

Contact

Dr. Marilyn DePietto:

Marilyn.m.depietto@hofstra.edu

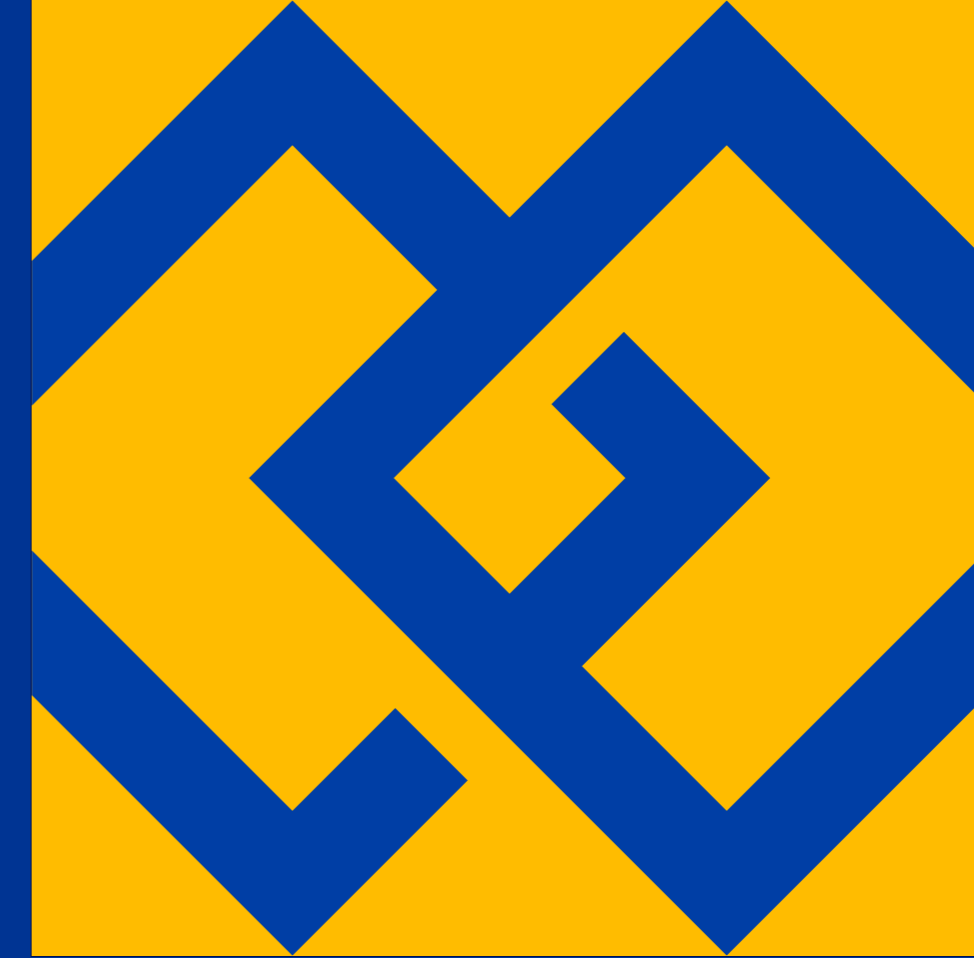



Please take this quick survey:
Fewer than 90 seconds!





Visit the RISE Webpage!



T

H

A

N

K

Y

O

U

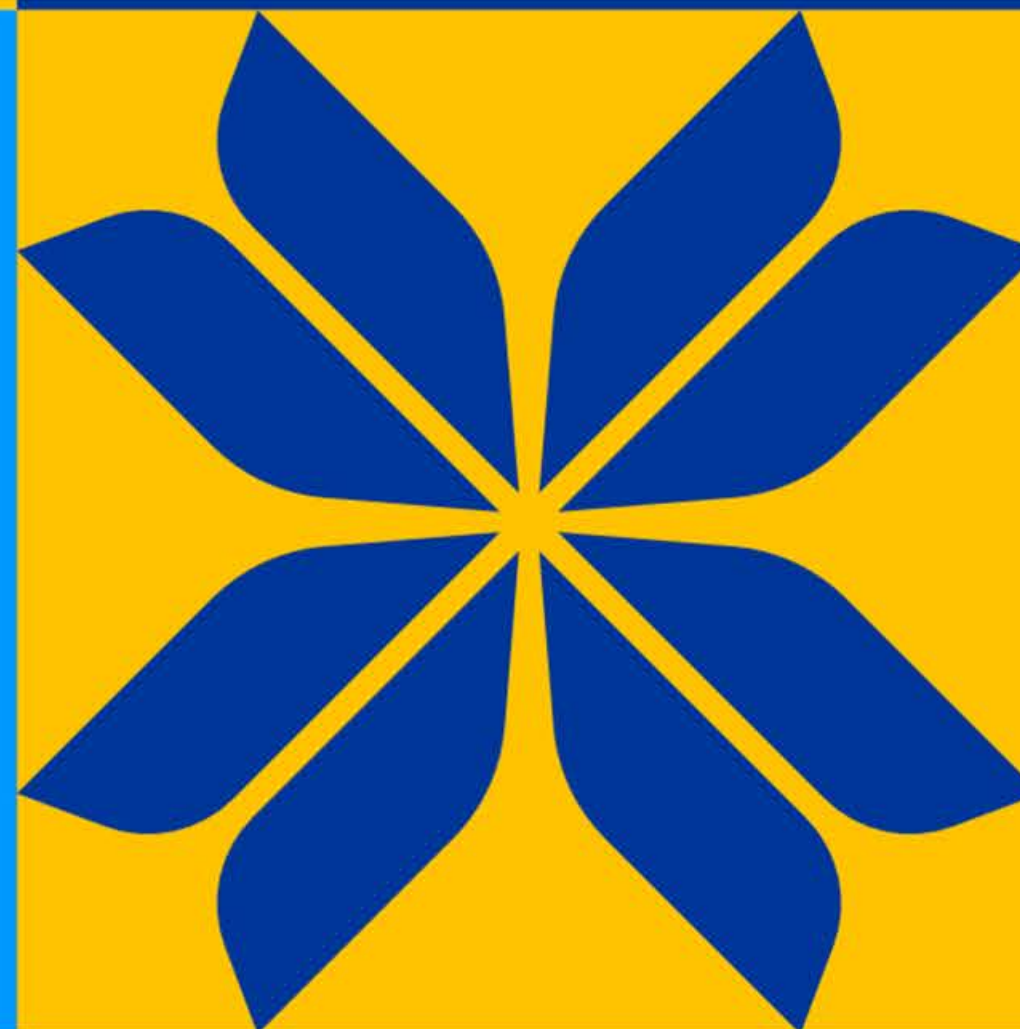

HOFSTRA
UNIVERSITY